



U. S. TRUCK BODY

BODY LANGUAGE

Aluminum • FRP • Freight Plate • Moving • Service Trade Van Bodies

Peaks to Perfection

We've designed our peaks for maximum size and load capacity.

On each side, heavy extruded aluminum rails are gusseted to steel logistic posts to form a full extension of each side. An FRP panel fits firmly into the side and front rails and is further supported from underneath with 2" x 3" aluminum cross members. The extruded aluminum (not roll formed) radius corners tie together the front posts and panels to the side walls to complete one of the strongest peaks in the industry.

Peaks are available in sizes of 24", 36", 48", 60", and 72".

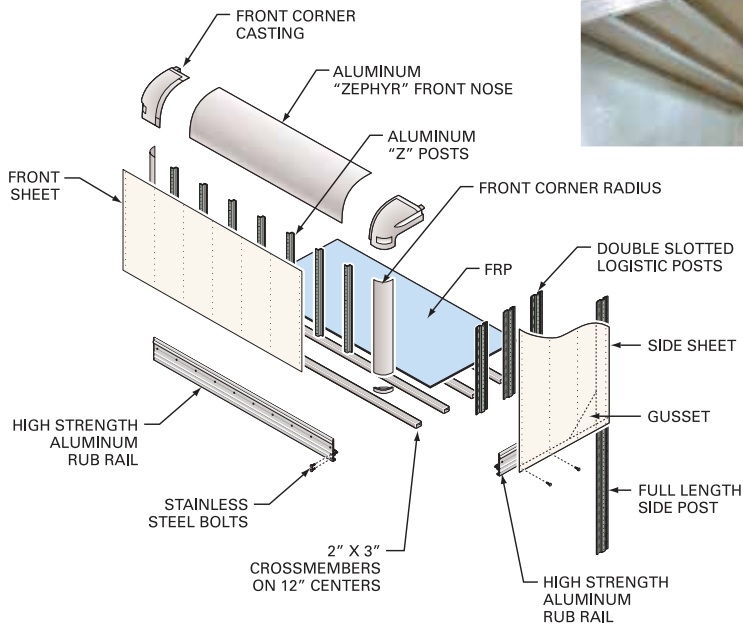

For more information about our Peaks or any other standard U.S. Truck Body quality feature, visit our web site at www.ustruckbody.com or contact us at 1-800-443-0843 or by fax at 815-672-1490.



U.S. Truck Body
1807 N. Bloomington Street
Streator, Illinois 61364

Designers and Builders of Truck Bodies for Over a Half Century.